



t h e

75



Z T



o w n e r s c l u b

OIL AND FILTER CHANGE Rover 75 / MG ZT KV6 models

1. Raise the car and support the vehicle with suitable axle stands
2. Remove the underbelly panel by releasing the fasteners (pic)

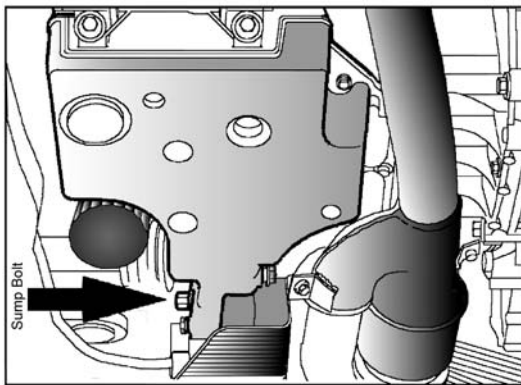
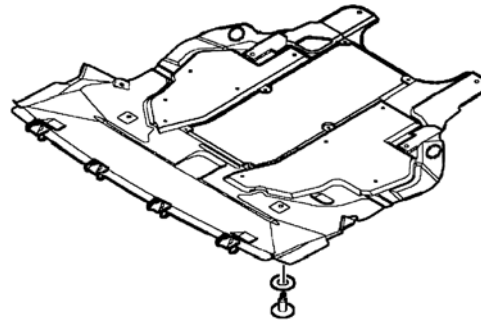

3. Locate the sump plug and place a shallow container underneath. Remove the plug.
4. Remove the oil filler cap, located on the camshaft cover, to allow the oil to drain smoothly
5. Locate the oil filter and remove
6. Fit new filter by hand until seated, then one further half-turn
7. Check oil has completely drained from the sump. If so, clean and refit the sump plug to 25Nm.
8. Fill engine using up to 5.19 Litres of 10W/40 oil meeting ACEA A2:96 specification. **DO NOT OVERFILL.** If in doubt fill to three-quarters and then add small amounts until the engine is just under full. Refit filler cap.
9. Start engine and watch for oil pressure light to disappear within a few seconds. Check for leaks
10. Refit underbelly panel and lower vehicle

DISCLAIMER: This document is intended as a guide only. You assume all responsibility for any problems you may have as a result of reading these instructions. The 75 and ZT Owners Club and the author of this document shall not be held responsible for any losses or injury caused by the use of this document.